

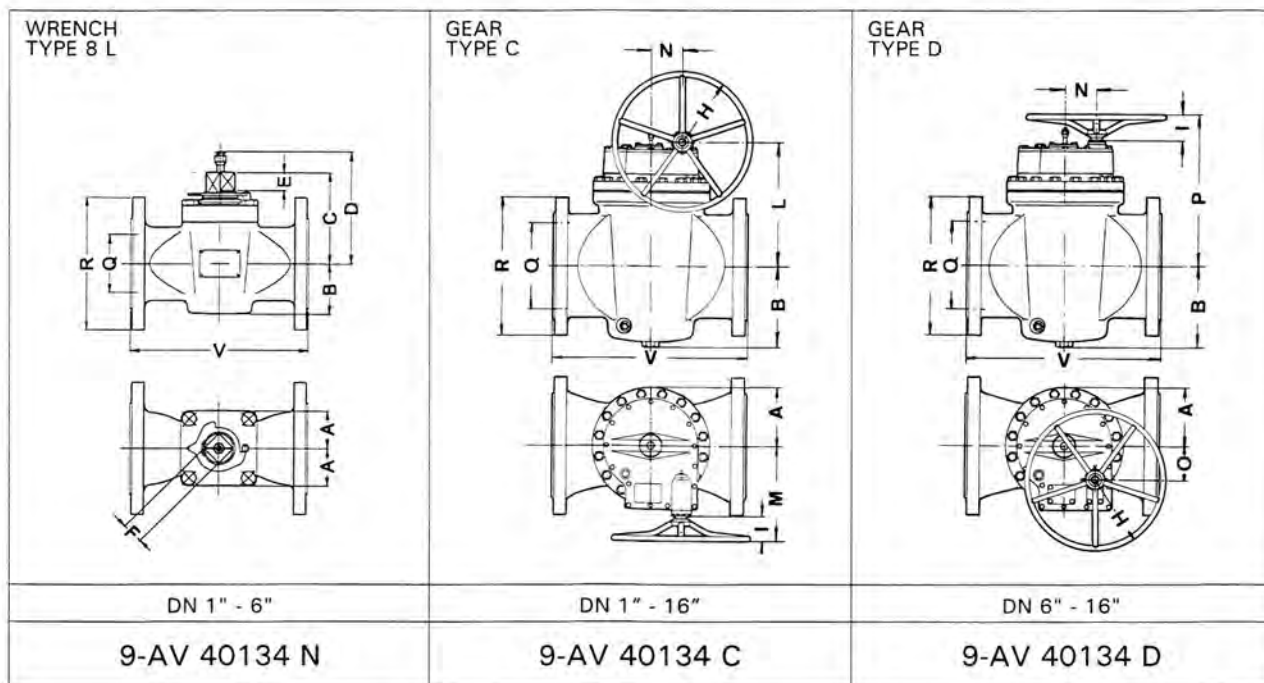

STRAIGHTWAY TAPER PLUG VALVES

CAST IRON CLASS 250
REGULAR PATTERN
RECTANGULAR PORT

Class	Max. CWP	Test Pressure	Pattern	Connections	Port	Materials		Operation
						Body & Cover	Plug	
250	≤ 12" 500 Psi ≥ 14" 300 Psi	Shell ≤ 12" 750 Psi ≥ 14" 450 Psi Seat ≤ 12" 550 Psi ≥ 14" 330 Psi	Straightway Regular	Flange R.F. ASME B 16.1 Face to Face ASME 16.10	Rectangular	Cast Iron ASTM A 126 Class B	Cast Iron ASTM A 126 Class B	Manual



DN	A	B	C	D	E	F	H	I	L	M	N	O	P	Q	R	V
1"	37	32	76	124	15	22	45	16	76	104	32			25	124	159
1 1/4"	37	40	86	134	17	22	45	16	83	104	32			32	133	*178
1 1/2"	40	49	92	140	18	22	45	16	98	104	32			38	155	191
2"	46	55	102	162	21	24	150	101	110	181	47			51	165	216
2 1/2"	52	65	120	180	22	27	150	101	122	181	47			64	191	241
3"	65	80	135	195	24	30	150	101	134	181	47			76	210	283
4"	90	93	160	240	31	36	150	101	150	195	65			102	254	305
5"	105	106	185	265	38	41	150	101	167	195	65			127	279	387
6"	130	126	206	286	42	50	200	101	252	268	85	46	375	152	318	426
8"	144	168	254	334	48	55	200	101	260	268	85	46	383	203	381	502
10"	183	190					300	101	334	293	95	70	458	254	445	597
12"	197	224					300	101	364	293	95	70	488	305	521	711
14"	235	247					300	101	441	361	135	69	575	337	584	*762
16"	250	295					300	101	466	400	160	108	600	387	648	*838