



# STRAIGHTWAY TAPER PLUG VALVES

CAST IRON CLASS 250  
REGULAR PATTERN  
RECTANGULAR PORT FULL BORE

Class	Max. CWP	Test Pressure	Pattern	Connections	Port	Materials		Operation
						Body & Cover	Plug	
250	500 Psi	Shell 750 Psi Seat 550 Psi	Straightway Regular	Screwed API 5B Table 2.1 or ASME B1.20.1	Rectangular Full bore **	Cast Iron ASTM A 126 Class B	Cast Iron ASTM A 126 Class B	Manual

\*\* 1/2" and 3/4" Round port full bore.

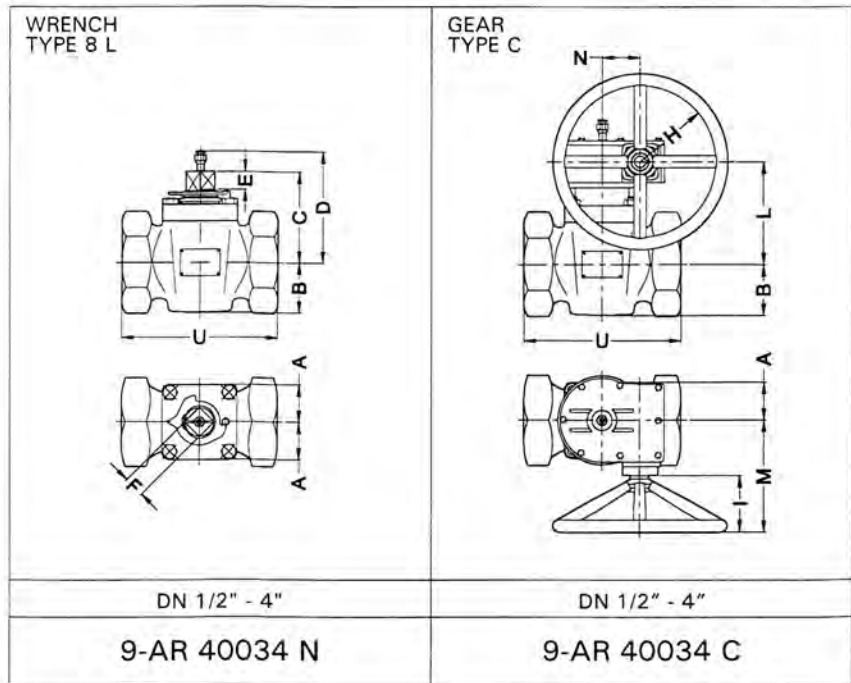

DN	A	B	C	D	E	F	H	I	L	M	N	U
1/2"	34	30	70	105	14	17	45	16	72	104	32	115
3/4"	37	32	76	124	15	22	45	16	76	104	32	115
1"	37	40	86	134	17	22	45	16	83	104	32	115
1 1/4"	40	49	92	140	18	22	45	16	98	104	32	130
1 1/2"	46	55	102	162	21	24	150	101	110	181	47	150
2"	52	65	120	180	22	27	150	101	122	181	47	160
2 1/2"	65	80	135	195	24	30	150	101	134	181	47	195
3"	90	93	160	240	31	36	150	101	150	195	65	220
4"	105	106	180	260	38	41	150	101	167	195	65	270