

# SEGURO

A RUBBER SEALED GATE VALVE

PN 16  
Non rising stem  
DN 350 - DN 1400

Class	Max. CWP	Test Pressure	Connections	Operation
PN 16	1600 kPa	Shell 2400 kPa Seat 1760 kPa	Flanges R.F. EN 1092-2 table 9 Face to Face EN 558-1 table 1, c14	Manual

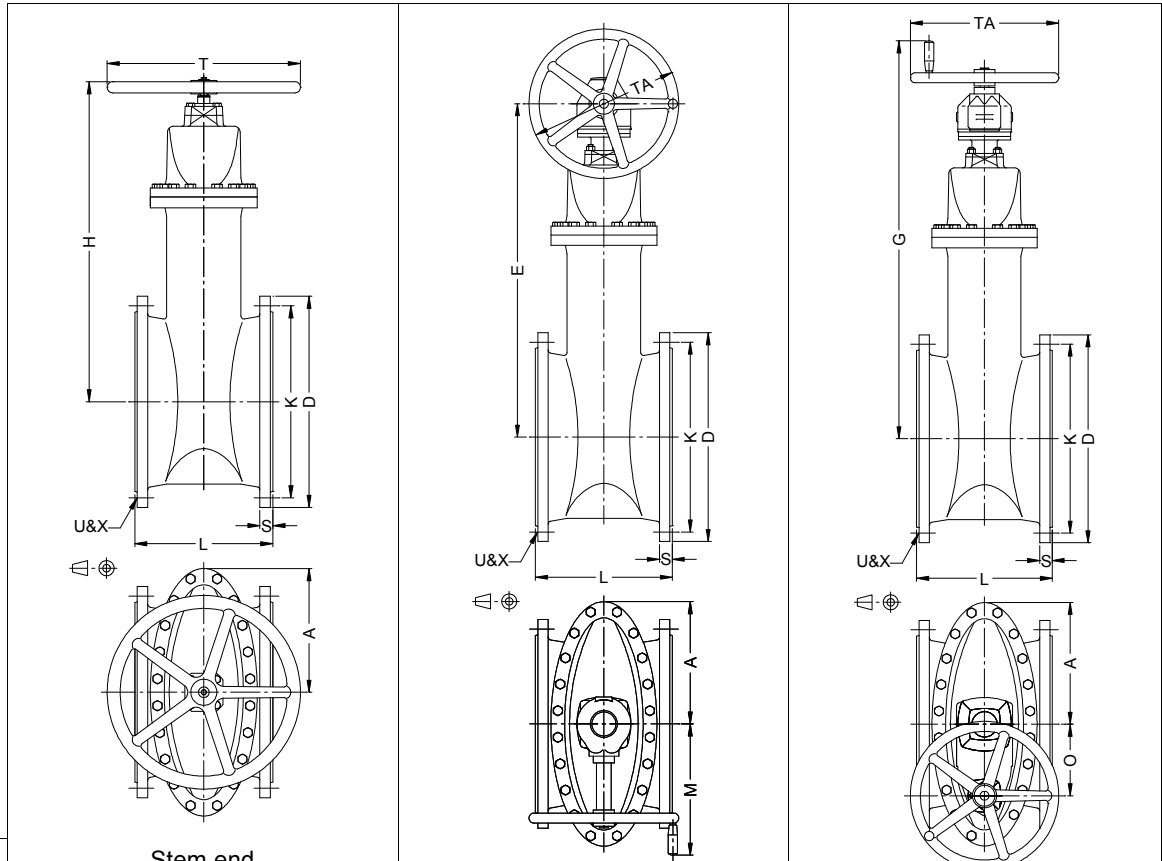

Materials		Stem end			
Body	Seal	Square	Hand wheel	Bevel gear and hand wheel	Spur gear and hand wheel
Grey Iron	NBR	12-TF 1211A	12-TF 1211AH	12-TF 1211AM	12-TF 1211AT
	EPDM	12-TF 1212A	12-TF 1212AH	12-TF 1212AM	12-TF 1212AT
Ductile Iron	NBR	12-TF 1231A	12-TF 1231AH	12-TF 1231AM	12-TF 1231AT
	EPDM	12-TF 1232A	12-TF 1232AH	12-TF 1232AM	12-TF 1232AT

Due to constant development of our products, minor deviations in the design and non-standardized dimensions may occur.

DN	A	D	E	G	H	K	L	M	O	S	T	TA	U	UU	X	XX
350	311	520	888	1109	820	470	290	366	240	36	500	400	16	4	28	M24
400	351	580	973	1194	919	525	310	366	240	38	500	400	16	4	31	M27
450	371	640	1059	1277	1000	585	330	366	240	40	640	400	20	4	31	M27
500	409	715	1119	1340	1067	650	350	366	240	42	640	500	20	4	34	M30
600	482	840	1321	1555	1253	770	390	439	300	48	720	500	20	6	37	M33
700	506	910	1484	1721	1456	840	430	439	300	54	720	500	24	6	37	M33
800	592	1025	1723	2050	1654	950	610*	439	300	58	800	640	24	-	41	M36
900	669	1125	1950	2226		1050	711*	454	360	62		640	28	-	41	M36
1000	761	1255	2363	2639		1170	864*	454	360	66		720	28	-	44	M39
1200	900	1485	2640	2914		1390	1070*	454	360	76*		720	32	-	50	M45
1400	970	1685	3041	3268		1590	1016*	558	380	82*		800	36	4	50	M45

Notes: \* Not included in the standard.

U = No. of bolts. UU = No. of threaded holes. X = Size of bolt holes. XX = Size of threaded holes.

Values for operating torque (on stem) and number of revolutions can be found on page C6.