

Class	Max. CWP	Test Pressure	Connections	Operation
250	300 Psi	Shell 450 Psi Seat 300 Psi	Flanges R.F. ASME B 16.1 Face to Face ASME B 16.10	Manual

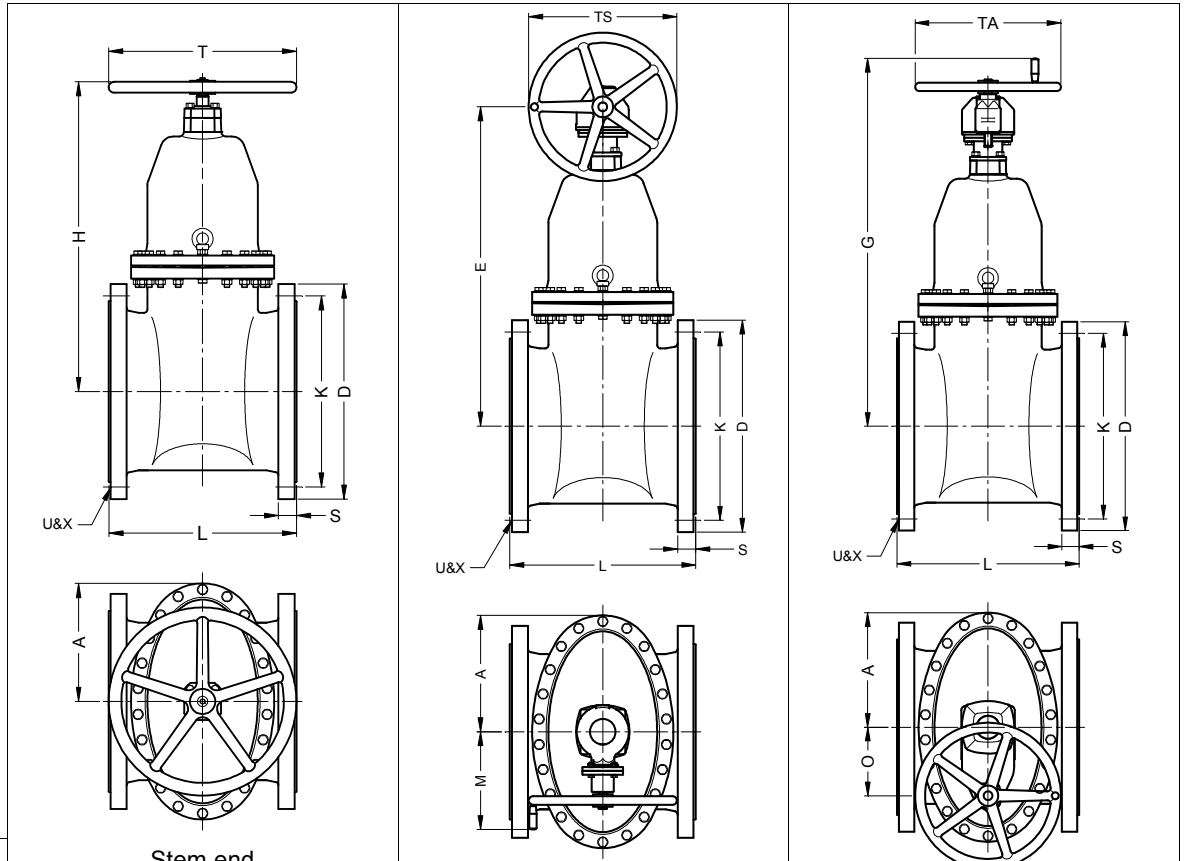

Materials		Stem end			
Body	Seal	Square	Hand wheel	Bevel gear and hand wheel	Spur gear and hand wheel
Grey Iron	NBR	12-A1311A	12-A1311AH	12-A1311AM	12-A1311AT
	EPDM	12-A1312A	12-A1312AH	12-A1312AM	12-A1312AT
Ductile Iron	NBR	12-A1331A	12-A1331AH	12-A1331AM	12-A1331AT
	EPDM	12-A1332A	12-A1332AH	12-A1332AM	12-A1332AT

Due to constant development of our products, minor deviations in the design and non-standardized dimensions may occur.

DN	A	D	E	G	H	K	L	M	O	S	T	TA	TS	U	X
16"	14,57	25,50	39,90	49,40	38,50	22,50	24	14,40	11,81	2,25	19,69	19,69	19,69	20	1,375
18"	16,10	28,00	43,30	54,60	41,20	24,75	26	14,40	11,81	2,38	25,20	19,69	19,69	24	1,375
20"	24,61	30,50	46,00	57,20	43,90	27,00	28	14,40	11,81	2,50	25,20	19,69	19,69	24	1,375
24"	19,80	36,00	55,10	66,40	52,40	32,00	31	14,40	11,81	2,75	28,35	19,69	19,69	24	1,625
30"	24,49	43,00	74,10	85,40		39,25	36*	21,85	14,17	3,00	31,50	25,20	23,62	28	2,000
36"	30,24	50,00	82,40	93,70		46,00	40*	21,85	14,17	3,38	31,50	25,20	23,62	32	2,250
42"	32,09	57,00	95,90	107,20		52,75	44*	21,85	14,17	3,69	35,43	28,35	27,56	36	2,250
48"	35,43	65,00	104,00	115,20		60,75	48*	30,00	14,96	4,00	39,37	28,35	27,56	40	2,250

Notes: * Not included in the standard.

U = No. of bolts, X = Size of bolt holes.

Values for operating torque (on stem) and number of revolutions can be found on page B8/I.