

SEGURO

A RUBBER SEALED GATE VALVE

Class 125
Non rising stem
DN 14" - DN 60"

Class	Max. CWP	Test Pressure	Connections	Operation
125	150 Psi	Shell 230 Psi Seat 150 Psi	Flanges F.F. ASME B 16.1 Face to Face ASME B 16.10	Prepared for Actuator

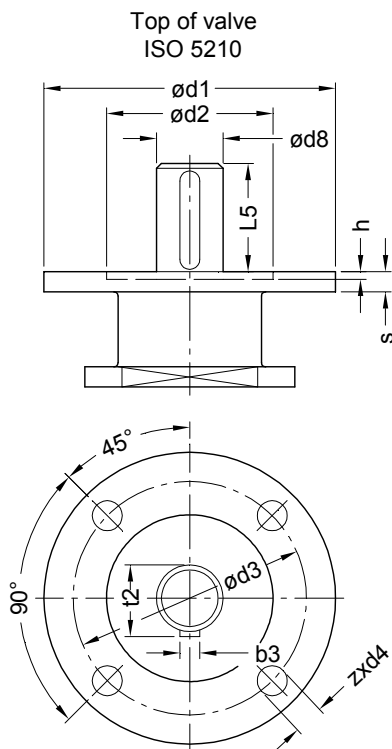

DN	Torque Nm	No. of turns Open/Close
14"	230	62
16"	290	70
18"	340	78
20"	410	74
24"	540	88
30"	830	102
36"	1000	106
42"	1165	117
48"	1580	102
54"	2580	119
60"	2880	135

Approximate operating torque and number of turns direct on stem.
Valid for all class 125 Seguro valves.
The seating torque is up to 10% higher.

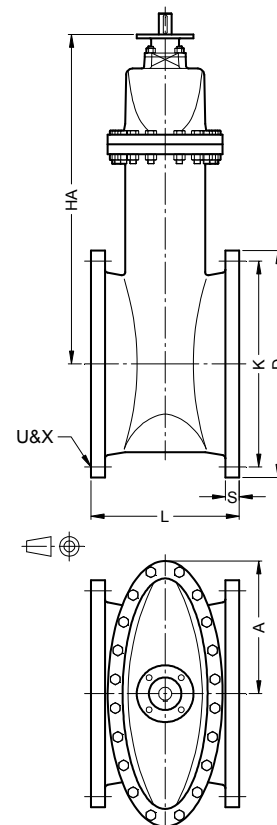

Flange for multiturn actuator

ISO 5210	$\phi d1$	$\phi d2$	$\phi d3$	$\phi d4$	h	s	z
F14	175	100	140	18	4,5	12	4
F16	210	130	165	22	5,5	16	4
F25	300	200	254	18	5,5	16	8
F30	350	230	298	22	5,5	18	8

Materials	
Body	Seal
Grey	NBR
Iron	EPDM
Ductile	NBR
Iron	EPDM

12-A 1111AL
12-A 1112AL
12-A 1131AL
12-A 1132AL

Due to constant development of our products, minor deviations in the design and non-standardized dimensions may occur.

DN	A	D	HA	K	L	S	U	X	b3	$\phi d8$	L5	t2	ISO 5210
14"	311	535	788	476	381	35,0	12	28,6	8	30	65	33,0	F14
16"	351	595	883	540	406	36,6	16	28,6	10	35	65	38,0	F14
18"	371	635	959	578	432	39,6	16	31,8	10	35	65	38,0	F14
20"	409	700	1019	635	457	42,9	20	31,8	12	40	65	43,0	F14
24"	482	815	1208	749	508	47,8	20	34,9	12	40	80	43,0	F16
30"	592	985	1610	914	610*	53,8	28	34,9	14	50	80	53,5	F16
36"	669	1170	1822	1086	711*	60,5	32	41,3	16	55	110	59,0	F25
42"	761	1345	2235	1257	864*	66,7	36	41,3	18	65	110	69,0	F25
48"	900	1510	2512	1422	1067*	69,9	44	41,3	25	90	110	95,0	F25
54"	970	1685	2858	1594	1016*	76,2	44	50,8	25	90	130	95,0	F30
60"	1067	1855	3103	1759	1118*	79,4	52	50,8	25	90	130	95,0	F30

Notes: * Not included in the standard.

U = No. of bolts, some of the holes might be threaded on DN 54" and larger. X = Size of bolt holes.