

Class	Max. CWP	Test Pressure	Connections	Operation
125	150 Psi	Shell 230 Psi Seat 150 Psi	Flanges F.F. ASME B 16.1 Face to Face ASME B 16.10	Manual

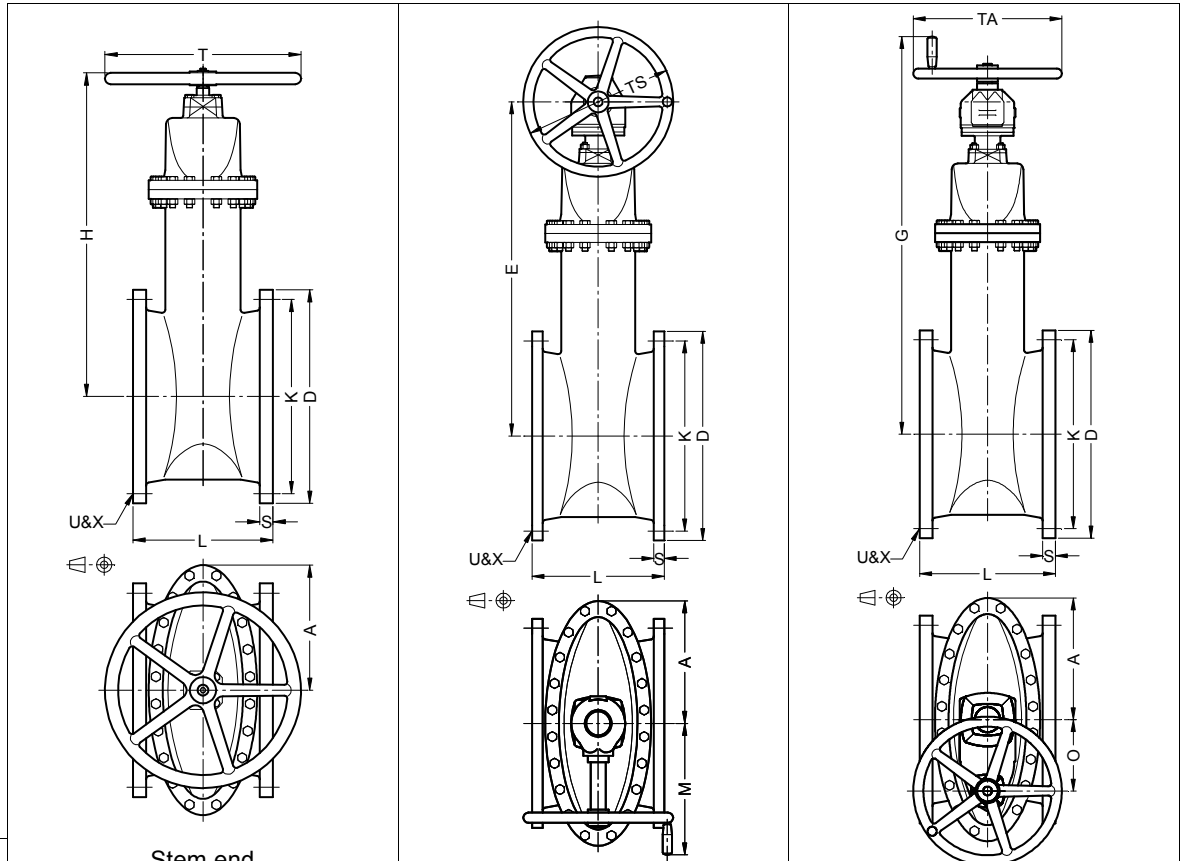

Materials		Stem end			
Body	Seal	Square	Hand wheel	Bevel gear and hand wheel	Spur gear and hand wheel
Grey Iron	NBR	12-A1111A	12-A1111AH	12-A1111AM	12-A1111AT
	EPDM	12-A1112A	12-A1112AH	12-A1112AM	12-A1112AT
Ductile Iron	NBR	12-A1131A	12-A1131AH	12-A1131AM	12-A1131AT
	EPDM	12-A1132A	12-A1132AH	12-A1132AM	12-A1132AT

Due to constant development of our products, minor deviations in the design and non-standardized dimensions may occur.

DN	A	D	E	G	H	K	L	M	O	S	T	TA	TS	U	X
14"	12,24	21,00	34,96	43,66	32,28	18,75	15	13,74	9,45	1,38	19,69	15,75	15,75	12	1,125
16"	13,82	23,50	38,31	47,01	36,18	21,25	16	13,74	9,45	1,44	19,69	15,75	15,75	16	1,125
18"	14,61	25,00	41,69	50,28	39,37	22,75	17	13,74	9,45	1,56	25,20	15,75	15,75	16	1,250
20"	16,10	27,50	44,06	52,76	42,01	25,00	18	13,74	9,45	1,69	25,20	19,69	19,69	20	1,250
24"	18,98	32,00	52,01	61,22	49,33	29,50	20	19,02	11,81	1,88	28,35	19,69	19,69	20	1,375
30"	23,31	38,75	67,83	77,09	65,12	36,00	24*	19,02	11,81	2,12	31,50	25,20	23,62	28	1,375
36"	26,34	46,00	76,77	87,64		42,75	28*	21,85	14,17	2,38	31,50	25,20	23,62	32	1,625
42"	29,96	53,00	93,03	103,90		49,50	34*	21,85	14,17	2,62	35,43	28,35	27,56	36	1,625
48"	35,43	59,50	103,94	114,72		56,00	42*	21,85	14,17	2,75	39,37	28,35	27,56	44	1,625
54"	38,19	66,25	119,72	128,66		62,75	40*	30,00	14,96	3,00		31,50	35,43	44	2,000
60"	42,01	73,00	129,37	139,02		69,25	44*	30,00	14,96	3,13		31,50	35,43	52	2,000

Notes: \* Not included in the standard.

U = No. of bolts, some of the holes might be threaded on DN 54" and larger. X = Size of bolt holes.

Values for operating torque (on stem) and number of revolutions can be found on page B2/I.